

*TB 9-6625-2050-24

DEPARTMENT OF THE ARMY TECHNICAL BULLETIN

CALIBRATION PROCEDURE FOR POWER METERS, TS-3793 (HEWLETT-PACKARD 436A AND 436AOPT9/22) HEWLETT-PACKARD MODELS 435A, 435B, 435BOPT001, AND 435BE21

Headquarters, Department of the Army, Washington, DC
9 January 2008

Distribution Statement A: Approved for public release; distribution is unlimited.

REPORTING OF ERRORS AND RECOMMENDING IMPROVEMENTS

You can improve this manual. If you find any mistakes or if you know of a way to improve these procedures, please let us know. Mail your letter or DA Form 2028 (Recommended Changes to Publications and Blank Forms) directly to: Commander, U.S. Army Aviation and Missile Command, ATTN: AMSAM-MMC-MA-NP, Redstone Arsenal, AL 35898-5000. A reply will be furnished to you. You may also send in your comments electronically to our E-mail address: 2028@redstone.army.mil or by fax 256-842-6546/DSN 788-6546. For the World Wide Web use: <https://amcom2028.redstone.army.mil>. Instructions for sending an electronic 2028 can be found at the back of this manual.

SECTION		Paragraph	Page
	I. IDENTIFICATION AND DESCRIPTION		
	Test instrument identification	1	2
	Forms, records, and reports	2	2
	Calibration description	3	2
	II. EQUIPMENT REQUIREMENTS		
	Equipment required.....	4	3
	Accessories required	5	3
	III. CALIBRATION PROCESS		
	Preliminary instructions	6	5
	Equipment setup.....	7	5
	Zero carryover (models 435A, 435B, 435BOPT001, and 435BE21).....	8	6
	Zero carryover (model 436A, and 436AOPT9/22) .	9	6
	Instrument accuracy (models 435A, 435B, 435BOPT001, and 435BE21)	10	9
	Instrument accuracy (models 436A and 436AOPT9/22	11	14

*This bulletin supersedes TB 9-6625-2050-35, 24 March 2004, including all changes.

SECTION		Paragraph	Page
III.	CALIBRATION PROCESS (CONTINUED)		
	Calibration factor (models 435A, 435B, 435BOPT001, and 435BE21.....)	12	16
	Calibration factor (models 436A and 436AOPT9/22	13	17
	Reference oscillator frequency accuracy (models 436A and 436AOPT9/22	14	18
	Power reference level.....	15	20
	Final procedure	16	21

SECTION I IDENTIFICATION AND DESCRIPTION

1. Test Instrument Identification. This bulletin provides instructions for the calibration of Power Meters, TS-3793 (Hewlett-Packard 436A and 436AOPT9/22), Hewlett-Packard Models 435A, 435B, 435BOPT001, and 435BE21. The manufacturers' manuals were used as the prime data sources in compiling these instructions. The equipment being calibrated will be referred to as the TI (test instrument) throughout this bulletin.

a. Model Variations. Some models come with three different range scales (removable rings) that correspond to the power sensors normally used with the test instrument. The three scales are mounted on the range switch. Make sure that the proper scale is selected for this calibration procedure and that the normal scale is replaced when the calibration process has been completed. Other variations among models are described in text tables and figures.

b. Time and Technique. The time required for this calibration is approximately 4 hours, using the microwave technique.

2. Forms, Records, and Reports

a. Forms, records, and reports required for calibration personnel at all levels are prescribed by TB 750-25.

b. Adjustments to be reported are designated (R) at the end of the sentence in which they appear. When adjustments are in tables, the (R) follows the designated adjustment. Report only those adjustments made and designated with (R).

3. Calibration Description. TI parameters and performance specifications which pertain to this calibration are listed in table 1.

Table 1. Calibration Description

Test instrument parameters	Performance specifications
Meter accuracy: Models 435A and 435B	Range: 10 μ W to 100 mW Accuracy: $\pm 1\%$ FS on all ranges
Models 436A and 436OPT9/22	Accuracy: $\pm 0.5\%$ FS watt mode: ± 0.02 dB, ± 0.001 dB/ $^{\circ}$ C, dB mode ± 0.02 dB, ± 0.001 dB/ $^{\circ}$ C, dB [REL] mode
Zero carryover: Models 435A, 435BOPT001, and 435BE21	$\pm 0.5\%$ FS (zeroed on most sensitive scale)
Models 436A and 436AOPT9/22	$\pm 0.2\%$ FS (zeroed on most sensitive scale)
Reference oscillator level (Models 435A, 435BOPT001, and 435BE21, 436A and 436AOPT9/22)	1 mW at 50 MHz $\pm 0.7\%$
Reference oscillator frequency (Models 436A and 436AOPT9/22)	50 MHz, $\pm 1\%$
Calibration factor (Models 435A, 435BOPT001, 435BE21, 436A, and 436AOPT9/22)	Range: 85 to 100% in 1% steps Accuracy: ± 6 mV

SECTION II EQUIPMENT REQUIREMENTS

4. Equipment Required. Table 2 identifies the specific equipment to be used in this calibration procedure. This equipment is issued with Secondary Transfer Calibration Standards Sets AN/GSM-286, AN/GSM-287, or AN/GSM-705. Alternate items may be used by the calibrating activity. The items selected must be verified to perform satisfactorily prior to use and must bear evidence of current calibration. The equipment must meet or exceed the minimum use specifications listed in table 2. The accuracies listed in table 2 provide a four-to-one ratio between the standard and TI. When the four-to-one ratio cannot be met, the actual accuracy of the equipment selected is shown in parenthesis.

5. Accessories Required. The accessories listed in table 3 are issued as indicated in paragraph 4 above and are used in this calibration procedure. When necessary, these items may be substituted by equivalent items, unless specifically prohibited.

Table 2. Minimum Specifications of Equipment Required

Common name	Minimum use specifications	Manufacturer and model (part number)
AUTOTRANSFORMER	Range: 105 to 125 V ac Accuracy: $\pm 1\%$	Ridge, Model 9020A (9020A),
FREQUENCY COUNTER	Range: 220 Hz to 50 MHz Accuracy: $\pm 0.25\%$	Fluke, Model PM6681/656 (PM6681/656)
MULTIMETER	Range: 200 mV to 1.19 V dc Accuracy: $\pm 0.06\%$	Agilent, Model 3458A (3458A)
OSCILLOSCOPE	Bandwidth: Dc to 50 MHz nominal	Agilent, OS-303/G (OS-303/G)
POWER METER	Range: 1 mW at 50 MHz ($\pm 0.2\%$)	Agilent, Model E12-432A (MIS-30525) w/thermistor mount, Agilent, Model 478A-H75 (7915907) or 8478B (8478B)
RANGE CALIBRATOR	Range: 3 μ W to 100 mW Accuracy: $\pm 0.25\%$ of setting	Agilent, Model 11683A

Table 3. Accessories Required

Common name	Description (part number)
EXTENDER BOARD ¹	Hewlett-Packard, P/N 5060-0258 24 pins
EXTENDER BOARD ¹	Hewlett-Packard P/N 5060-0630 44 pins
POWER SENSOR	Agilent, Model 8481 or 8482A/H
RUBBER BUMPERS ¹	Hewlett-Packard P/N 0403-0115
TEST LEAD ²	30-in., RG-58/U; double banana plug to probe and alligator clip (7911305)

¹ Additional equipment required to enhance access to adjustments.

² Three required.

SECTION III CALIBRATION PROCESS

6. Preliminary Instructions

a. The instructions outlined in paragraphs 6 and 7 are preparatory to the calibration process. Personnel should become familiar with the entire bulletin before beginning the calibration.

b. Items of equipment used in this procedure are referenced within the text by common name as listed in tables 2 and 3.

c. Unless otherwise specified, verify the result of each test and, whenever the test requirement is not met, take corrective action before continuing with the calibration. Adjustments required to calibrate the TI are included in this procedure. Additional maintenance information is contained in the manufacturers' manuals for this TI.

d. Unless otherwise specified, all controls and control settings refer to the TI.

7. Equipment Setup

WARNING

HIGH VOLTAGE is used or exposed during the performance of this calibration. DEATH ON CONTACT may result if personnel fail to observe safety precautions. REDUCE OUTPUTS(S) to minimum after each step within the performance check where applicable.

- a. Connect TI to autotransformer.
- b. Connect autotransformer to a 115 V ac source and adjust for a 115 V ac output.
- c. Set **LINE** switch to **ON** and allow 30 minutes for TI to warm-up and stabilize.

CAUTION

To avoid damage to meter, set range calibrator **FUNCTION** switch to **STANDBY** while changing **RANGE** switch settings on TI and range calibration.

NOTE

If an out-of-tolerance indication is obtained during any performance check, re-zero TI as follows: Set range calibrator **FUNCTION** switch to **STANDBY**, then press TI **ZERO** (model 435A) switch and wait for meter zero indication (model 435A) to stabilize.

8. Zero Carryover (Models 435A, 435B, 435BOPT001, and 435BE21)

a. Performance Check

- (1) Connect multimeter to **RECORDER OUTPUT** (rear panel).
- (2) Connect power sensor using power sensor cable (p/o TI).
- (3) Set switches as listed in (a) through (c) below:
 - (a) **CAL FACTOR** % to **100**.
 - (b) **POWER REF** to **OFF** (out) (rear panel).
 - (c) **RANGE** to **3 μ W**.
- (4) Press **ZERO** pushbutton and wait for meter indicators position to stabilize. Multimeter will indicate between -0.9 and +0.9 mV dc. Release **ZERO** pushbutton; multimeter will indicate between -15 and +15 mV dc.
- (5) Set **RANGE** switch as listed in table 4. Multimeter will indicate within limits specified.

Table 4. Zero Carryover (Models 435A, 435B, 435BOPT001, and 435BE21)

RANGE switch position	Results mV dc	
	Min	Max
10 μ W	-17	+17
30 μ W	-14	+14
100 μ W	-11	+11
300 μ W	-8	+8
1 mW	-5	+5
3 mW	-5	+5
10 mW	-5	+5
30 mW	-5	+5
100 mW	-5	+5

b. **Adjustments.** No adjustments can be made.

9. **Zero Carryover (Models 436A and 436AOPT9/22)**

a. **Performance Check**

(1) Connect range calibrator to TI **POWER SENSOR INPUT** cable (supplied with TI).

(2) Position controls as listed in (a) through (d) below:

- (a) Set **CAL FACTOR %** switch to **100**.
- (b) Press **POWER REF** pushbutton to **OFF** (out).
- (c) Press **MODE WATT** pushbutton.
- (d) Press **RANGE HOLD** pushbutton to off (out).

(3) Position range calibrator controls as listed in (a) through (d) below:

- (a) **FUNCTION** switch to **STANDBY**.
- (b) **POLARITY** switch to **NORMAL**.
- (c) **RANGE** switch to **100 μ W**.
- (d) **LINE** pushbutton to **ON** (in).

(4) Press and hold **SENSOR ZERO** pushbutton and wait for digital readout to stabilize. Verify that **ZERO** lamp is lit and digital readout indicates between -0.02 and +0.02.

NOTE

TI is now zeroed on most sensitive range (10 μ W).

(5) Release **SENSOR ZERO** pushbutton and wait for **ZERO** lamp to extinguish before proceeding.

(6) Set range calibrator **FUNCTION** switch to **CALIBRATE** and verify TI autoranges to 100 μ W range.

(7) Set **RANGE HOLD** pushbutton to on (in) and range calibrator **FUNCTION** switch to **STANDBY**.

(8) Wait for TI digital readout to stabilize. If TI does not indicate between +00.2 and -00.2 μ W, perform **b** below.

(9) Set **RANGE HOLD** pushbutton to off (out).

(10) Repeat technique of (6) through (9) above at TI and range calibrator switch positions listed in table 5. If TI does not indicate within limits specified, perform **b** below.

Table 5. Zero Carryover Autorange (Models 436A and 436AOPT9/22)

Range calibrator switch settings and TI meter RANGE indications (mW)	Test instrument indications (mW)	
	Min	Max
1	-.002	+.002
10	-0.02	+0.02
100	-00.2	+00.2

b. Adjustments

(1) Set range calibrator **RANGE** switch to **100 mW** and **FUNCTION** switch to **CALIBRATE**. Verify that TI autoranges to 100 mW range, then set the **RANGE HOLD** pushbutton to on (in).

(2) Set range calibrator **FUNCTION** switch to **STANDBY**.

(3) Adjust **DC OFF** potentiometer A3R2 (fig. 1) for a digital readout of **00.0** with a blinking minus sign (R).

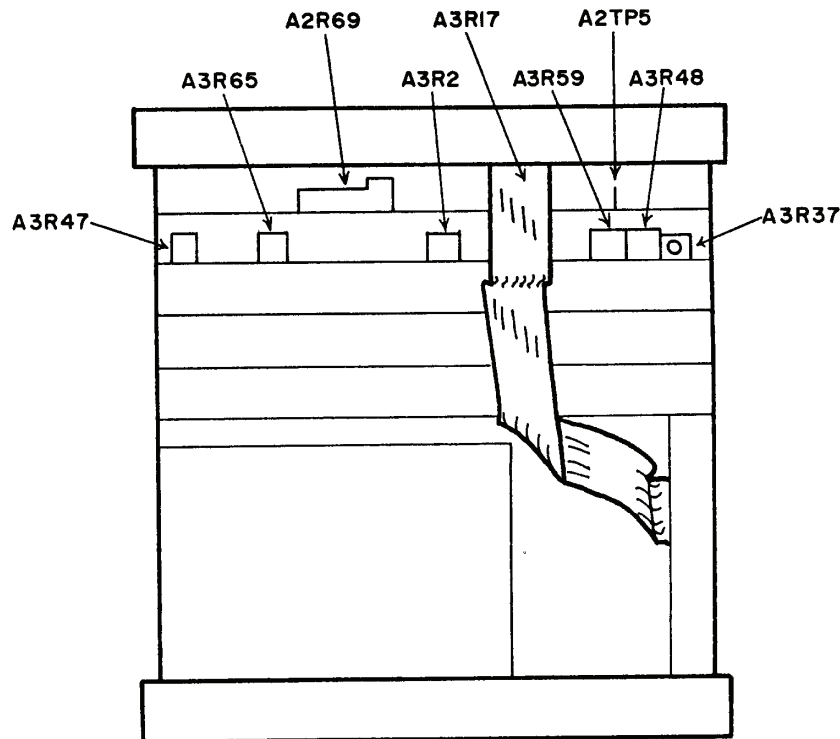

Figure 1. Models 436A and 436AOPT9/22 - adjustment locations.

- (4) Set **RANGE HOLD** pushbutton to off (out).
- (5) Verify that TI autoranges to 10 μW range.
- (6) Press and hold **SENSOR ZERO** pushbutton and adjust **ZERO OFF** potentiometer A3R47 (fig. 1) until digital readout indicates **0.00** with blinking minus sign (R).

NOTE

Do not perform (7) through (11) below unless indication in (6) above could not be obtained.

- (7) Set range calibrator **FUNCTION** switch to **CALIBRATE** and **RANGE** switch to **100 μW** .
- (8) Adjust TI front-panel **CAL ADJ** control until digital readout indicates **100 μW** .
- (9) Press and hold **SENSOR ZERO** pushbutton and adjust **BAL** potentiometer A3R65 (fig. 1) until display readout indicates **60.0 μW** (R).
- (10) Set range calibrator **FUNCTION** switch to **STANDBY**. Press **SENSOR ZERO** pushbutton and wait for digital readout to stabilize.
- (11) Press **SENSOR ZERO** pushbutton and wait for display readout to stabilize. Release **SENSOR ZERO** pushbutton and wait for **ZERO** light to extinguish.

10. Instrument Accuracy (Models 435A, 435B, 435BOPT001, and 435BE21)

a. Performance Check

- (1) Connect range calibrator to TI **POWER SENSOR** input, using cable supplied with TI.
- (2) Connect multimeter to **RECORDER OUTPUT** (rear panel).
- (3) Set range calibrator switches as listed in (a) through (c) below:
 - (a) **RANGE** to **1 mW**.
 - (b) **FUNCTION** to **CALIBRATE**.
 - (c) **POLARITY** to **NORMAL**.
- (4) Set TI **RANGE** switch to **1 mW**.
- (5) Adjust TI (front panel) **CAL ADJ** for a 1000 ± 2 mV dc indication on multimeter. Verify that TI meter indication is between 0.99 and 1.01; if not, perform **b** (1) below.
- (6) Set TI and range calibrator **RANGE** switches to **3 μW** . If multimeter does not indicate between 975 and 1,025 mV dc, perform **b** (2) through (20) below.
- (7) Set TI and range calibrator **RANGE** switch to positions listed in table 6. TI and multimeter will indicate within limits specified.

Table 6. Instrument Accuracy (Model 435A, 435B, 435BOPT001, and 435BE21)

Test instrument and range calibrator RANGE switch positions (mW)	Multimeter indications (mV)	
	Min	Max
10 μ W	978	1022
30 μ W	981	1019
100 μ W	984	1016
300 μ W	987	1013
1 mW	998	1002
3 mW	990	1010
10 mW	990	1010
30 mW	990	1010
100 mW	990	1010

b. Adjustments

- (1) Adjust A4R35 (fig. 2) for a 1 V indication on TI meter.
- (2) Set TI **LINE** switch to **OFF**. If TI meter does not indicate **0** (zero), adjust to **0** using adjustment screw located below meter face.
- (3) Set switches as listed in (a) through (d) below:
 - (a) **CAL FACTOR** % to **100**.
 - (b) **RANGE** to **100 mW**.
 - (c) **POWER REF** (rear panel) to **OFF**.
 - (d) **LINE** to **ON**.
- (4) Set range calibrator switches as listed in (a) through (c) below:
 - (a) **RANGE** to **1 mW**.
 - (b) **FUNCTION** to **STANDBY**.
 - (c) **POLARITY** to **NORMAL**.
- (5) Connect frequency counter between A4TP8 (fig. 2) and ground. If frequency counter does not indicate between 204 and 236 Hz, for model 435A, or between 208 and 232 Hz for model 435B, perform (6) through (10) below. If frequency counter is within limits, proceed to (11) below.
- (6) Connect equipment as shown in figure 3.
- (7) Set range calibrator **FUNCTION** switch to **CALIBRATE**.
- (8) Position oscilloscope controls as listed in (a) through (e) below:
 - (a) **MODE CH 1** and **CH 2** selected.
 - (b) **CHOP/ALT** button selected for **CHOP** vertical display mode.
 - (c) **CH 1 VOLTS/DIV** to **0.05 V/div** and **AC** coupled.
 - (d) **CH 2 VOLTS/DIV** to **0.2 V/div** and **AC** coupled.
 - (e) **SEC/DIV** to **0.5 ms/div**.

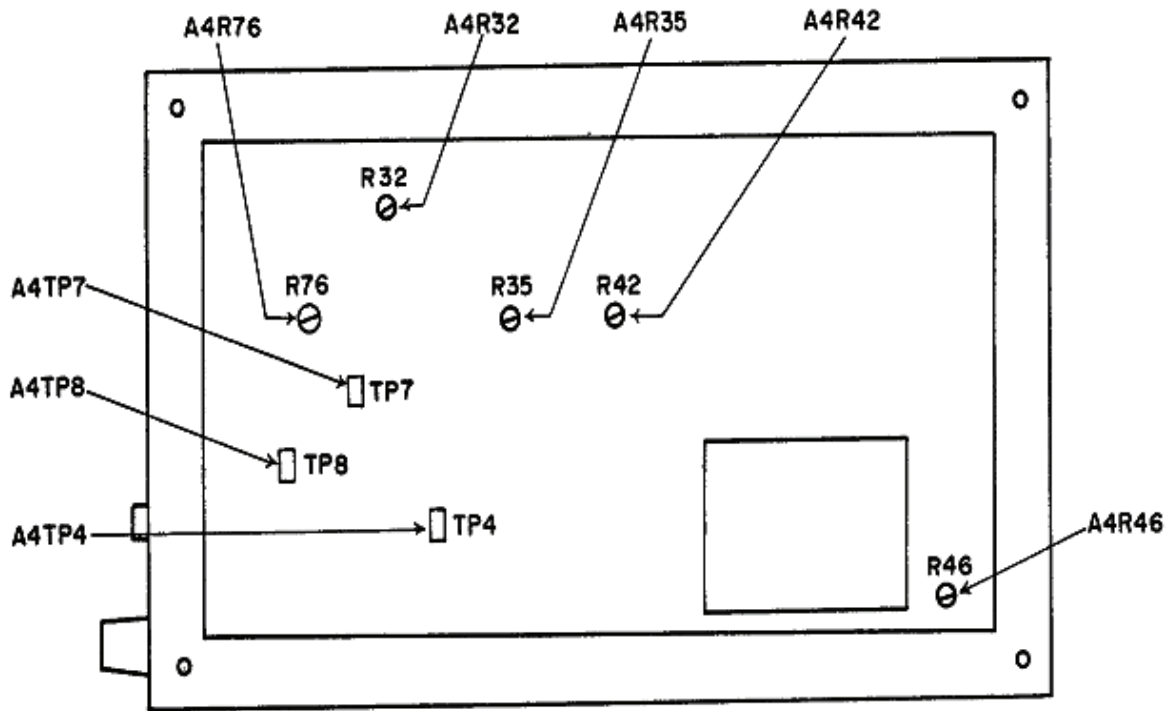

Figure 2. Model 435A - right view.

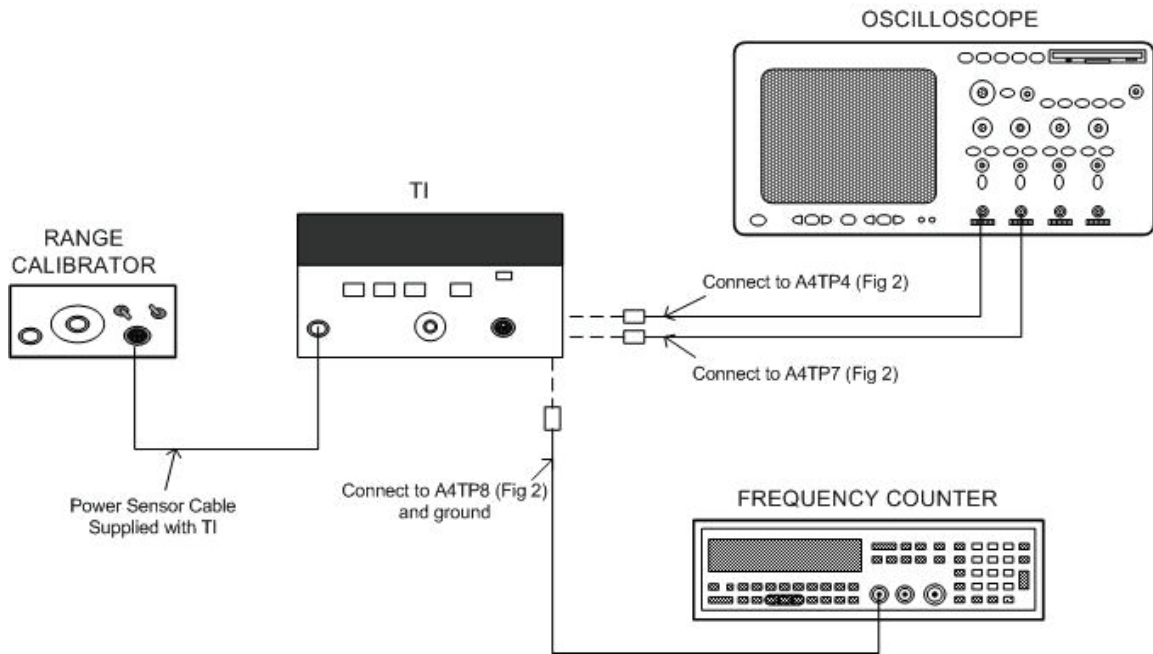

Figure 3. Model 435A multivibrator adjustment - equipment setup.

(9) Adjust oscilloscope and range calibrator controls to superimpose waveforms as shown in figure 4, using procedure in (a) through (d) below.

(a) Establish a horizontal grid line as dc average of test point A4TP4 (fig. 2) by setting range calibrator **FUNCTION** switch to **STANDBY**.

(b) Position **CH 1** trace on the line.

(c) Set range calibrator **FUNCTION** switch to **CALIBRATE**.

(d) Press oscilloscope **X10 MAG** button to activate.

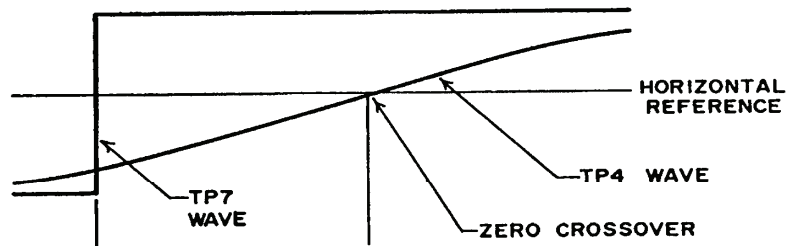

MSC04085

Figure 4. Zero crossover waveform.

(10) Adjust A4R76 (fig. 2) until zero crossover lags the square wave 150 μ s (R).

(11) Repeat (3) above.

(12) Position A4R46 (fig. 2) to its mechanical center position.

(13) Adjust A4R32 (fig. 2) until multimeter indicates 0 ± 0.2 mV dc (R).

(14) Set range calibrator **FUNCTION** switch to **CALIBRATE** and TI range to **1 mW**.

(15) Adjust **CAL ADJ** until multimeter indicates $1,000 \pm 1$ mV dc.

(16) Adjust A4R35 (fig. 2) until TI meter indicates full scale (R).

(17) Set range calibrator to **STANDBY**.

(18) Set **RANGE** switch to **3 μ W** and press and hold **ZERO** switch. Adjust A4R42 (fig. 2) until multimeter indicates 0 mV dc (R). Release **ZERO** switch.

(19) Set TI **RANGE** switch to **1 mW**.

(20) Set range calibrator **FUNCTION** switch to **CALIBRATE**.

(21) Press and hold **ZERO** switch. Adjust A4R46 (fig. 2) until multimeter indicates 961 mV dc (R). Release **ZERO** switch.

11. Instrument Accuracy (Models 436A and 436AOPT9/22)

a. Performance Check

- (1) Position controls as listed in (a) through (d) below:
 - (a) **CAL FACTOR** % switch to **100**.
 - (b) **POWER REF** pushbutton to off (out).
 - (c) **MODE** switch to **WATT**.
 - (d) **RANGE HOLD** pushbutton to off (out).
- (2) Set range calibrator switches as listed in (a) through (c) below:
 - (a) **FUNCTION** to **STANDBY**.
 - (b) **POLARITY** to **NORMAL**.
 - (c) **RANGE** to **1 mW**.
- (3) Press and hold **TI SENSOR ZERO** pushbutton and wait for digital readout to stabilize. **ZERO** lamp will be illuminated and digital readout will indicate between -0.02 and +0.02.

NOTE

TI is now zeroed on the most sensitive range (10 μ W).

- (4) Release **SENSOR ZERO** pushbutton and wait for **ZERO** lamp to extinguish before proceeding.
- (5) Set range calibrator **FUNCTION** switch to **CALIBRATE** and verify that TI autoranges to 1 mW range.
- (6) Observe digital readout and, if necessary, adjust front panel **CAL ADJ** control to obtain a **1.000 mW** indication.

NOTE

Range calibrator output level is adjustable in 5 dB increments. Thus, the 3 μ W, 30 μ W, 300 μ W, 3 mW, and 30 mW legends on the **RANGE** switch are approximations. The true outputs for these settings are 3.16 μ W, 31.6 μ W, 316 μ W, 3.16 mW, and 31.6 mW.

- (7) Connect multimeter to TI recorder output (rear panel).
- (8) Set range calibrator to **RANGE** switch positions listed in table 7. If TI does not indicate within limits, perform **b** below.
- (9) Set range calibrator **RANGE** switch to **-10 dBm**.
- (10) Press TI **MODE** pushbutton to **dB (REF)**. TI digital readout will indicate between -0.01 and +0.01.
- (11) Set range calibrator **RANGE** switch and TI **RANGE** switches to settings listed in table 8. If TI does not indicate within limits specified, perform **b** below.

Table 7. Instrument Accuracy (Model 436A and 436AOPT9/22)

Range calibrator switch settings and test instrument meter RANGE indications	Test instrument digital display indications		Multimeter indications (V dc)	
	Min	Max	Min	Max
10 μ W	9.95 μ W	10.05 μ W	0.995	1.005
100 μ W	99.5 μ W	100.5 μ W	0.995	1.005
1 mW	0.995 mW	1.005 mW	0.995	1.005
10 mW	9.95 mW	10.05 mW	0.995	1.005
100 mW	99.5 mW	100.5 mW	0.995	1.005
-20 dBm ¹	-20.02 dBm	-19.98 dBm	0.995	1.005
-10 dBm	-10.02 dBm	-9.98 dBm	0.995	1.005
0 dBm	-0.02 dBm	0.02 dBm	0.995	1.005
+10 dBm	9.98 dBm	10.02 dBm	0.995	1.005
+20 dBm	19.98 dBm	20.02 dBm	0.995	1.005

¹Press TI **MODE dBm** pushbutton.

Table 8. Instrument Accuracy dB (REF) Mode (Models 436A and 436AOPT9/22)

Range calibrator switch settings (dBm)	Test instrument meter RANGE indications (dB (REL))	
	Min	Max
-20	-9.96	-10.04
-5	+4.96	+5.04
+10 dBm	+19.96	20.04

b. Adjustments

- (1) Press TI **LINE** pushbutton to **OFF** (out) and **MODE** pushbutton to **WATT**.
- (2) Set range calibrator **FUNCTION** switch to **CALIBRATE** and **POLARITY** switch to **NORMAL**.
- (3) Connect frequency counter to A2TP5 (fig. 1).

NOTE

PC extender board and rubber bumpers should be installed to extender board to prevent board from touching.

- (4) Press TI **LINE** pushbutton to **ON** (in).
- (5) Adjust **FREQ** potentiometer A2R69 (fig. 1) to obtain maximum indication on TI digital readout and verify that frequency counter indicates 220 Hz (R).
- (6) Repeat a above, and if TI does not indicate within limits specified, perform (7) through (18) below.
- (7) Disconnect counter from TI.
- (8) Connect multimeter to TI **RECORDER OUTPUT** (rear panel).
- (9) Set range calibrator **FUNCTION** switch to **STANDBY** and **RANGE** switch to **1 mW**.

(10) Press **SENSOR ZERO** pushbutton and wait for display readout to stabilize. Release **SENSOR ZERO** pushbutton and wait for **ZERO** light to extinguish.

(11) Set range calibrator **FUNCTION** switch to **CALIBRATE** and adjust front panel **CAL ADJ** for 1.000 V dc indication on multimeter.

(12) Adjust LIN potentiometer A3R37 (fig. 1) until TI digital readout indicates **1.000 mW** (R).

(13) Press **MODE** and **RANGE HOLD** pushbuttons to **dBm** and **ON** respectively.

NOTE

The next step sets the A-D log threshold. When specified indication (-10.00) is obtained, digital readout should be just on the verge of blanking, that is, readout may randomly alternate between -10.00 and under range, -1.

(14) Set range calibrator **RANGE** switch to **-10 dBm** and adjust LZR A3R59 (fig. 1) for -10 dBm (R).

(15) Press **RANGE HOLD** pushbutton to **OFF** and range calibrator **RANGE** switch to **1 mW**.

(16) Adjust LFS potentiometer A3R48 (fig. 1) until TI digital readout indicates **-0.00** (R).

(17) Press **MODE** pushbutton to **WATT** and adjust MTR A3R17 (fig. 1) until pointer is half-way between last two marks on meter face (R).

12. Calibration Factor (Models 435A, 435B, 435BOPT001, and 435BE21)

a. Performance Check

(1) Connect range calibrator to TI **POWER SENSOR** cable supplied with TI.

(2) Connect multimeter to TI **RECORDER OUTPUT** (rear panel).

(3) Set TI **RANGE** switch to **1 mW**.

(4) Position range calibrator switches as indicated in (a) through (c) below:

(a) **RANGE** to **1 mW**.

(b) **FUNCTION** to **CALIBRATOR**.

(c) **POLARITY** to **NORMAL**.

(5) Adjust TI **CAL ADJ** control for a **1.000 V dc** indication on multimeter.

(6) Set TI **CAL FACTOR** % switch to positions listed in table 9. Multimeter will indicate within limits specified.

b. Adjustments. No adjustments can be made.

Table 9. Calibrator Factor (Models 436A, 435A, 435B, 435BOPT001, and 435BE21)

Test instrument CAL FACTOR % switch settings	Test instrument multimeter indications (V dc)	
	Min	Max
100	0.994	1.006
99	1.004	1.016
98	1.014	1.026
97	1.025	1.037
96	1.036	1.048
95	1.047	1.059
94	1.058	1.070
93	1.069	1.081
92	1.081	1.093
91	1.093	1.105
90	1.105	1.117
89	1.118	1.130
88	1.130	1.142
87	1.143	1.155
86	1.157	1.169
85	1.170	1.182

13. Calibration Factor (Model 436A and 436AOPT9/22)

a. Performance Check

- (1) Connect range calibrator to TI **POWER SENSOR INPUT** cable supplied with TI.
- (2) Position controls as listed in (a) through (d) below:
 - (a) **CAL FACTOR** % switch to **100**.
 - (b) **POWER REF** pushbutton to off (out).
 - (c) **MODE** pushbutton to **WATT**.
 - (d) **RANGE HOLD** pushbutton to off (out).
- (3) Set range calibrator switches as listed in (a) through (c) below:
 - (a) **FUNCTION** to **STANDBY**.
 - (b) **POLARITY** to **NORMAL**.
 - (c) **RANGE** to **1 mW**.
- (4) Press and hold TI **SENSOR ZERO** pushbutton and wait for digital readout to stabilize. TI **ZERO** lamp will be illuminated and digital readout will indicate between -0.02 and +0.02.

NOTE

TI is now zeroed on most sensitive range (10 μ W).

- (5) Release TI **SENSOR ZERO** pushbutton and wait for **ZERO** lamp to extinguish before proceeding.

(6) Set range calibrator **FUNCTION** switch to **CALIBRATE** and verify that TI autoranges to **1 mW** range.

(7) Adjust TI **CAL ADJ** control to obtain a **1.000** indication on digital readout.

(8) Set **CAL FACTOR** % switch to positions listed in table 9. TI will indicate within limits specified.

b. Adjustments. No adjustments can be made.

14. Reference Oscillator Frequency Accuracy (Models 436A and 436AOPT9/22)

a. Performance Check

(1) Press TI **LINE** pushbutton to **ON** and **POWER REF** pushbutton to **OFF**.

(2) Connect TI **POWER REF OUTPUT** connector to frequency counter and adjust counter to measure frequency of 50.0 MHz.

(3) Set TI **POWER REF** pushbutton **ON** and observe indication on the counter. If frequency counter does not indicate between 49.5 and 50.5 MHz, perform **b** below.

b. Adjustments

(1) Remove power meter top cover.

NOTE

Take care not to ground +15 V or -15 V inputs to power reference oscillator when performing **b** (2) through (6). Grounding either of these inputs could damage power reference oscillator and/or power supply.

(2) Grasp power reference oscillator assembly firmly, and remove four screws which secure it to power meter chassis.

(3) Tilt power reference oscillator assembly to gain access to circuit board underneath metal cover, and adjust A8L1 (**FREQ ADJ**) (fig. 5) to obtain a 50.00 MHz indication on counter (R).

(4) Reposition power reference oscillator on power meter chassis but do not replace mounting screws.

(5) Observe indication on the counter. If it is 50.0 MHz, the adjustment procedure is complete. If it is not within these limits, repeat **b** (3) except offset power reference oscillator frequency as required to obtain a **50.0 MHz** indication on counter when power reference oscillator assembly is repositioned on power meter chassis.

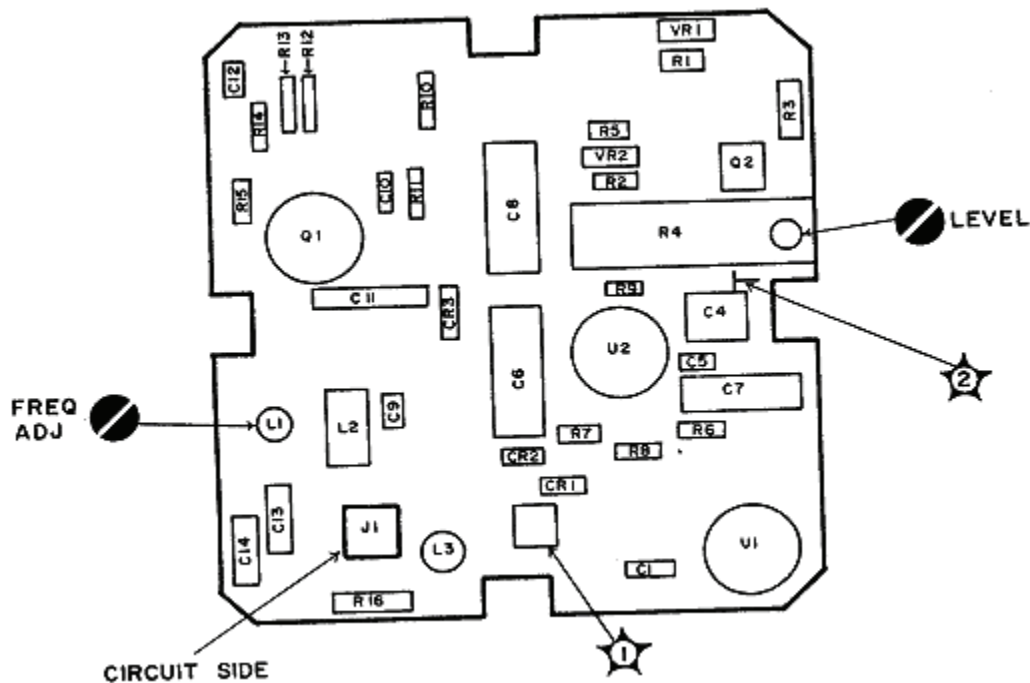

Figure 5. REF FREQ and LEVEL adjustments.

15. Power Reference Level

a. Performance Check

(1) With power meter off, remove thermistor mount from interconnect cable. Adjust multimeter to measure resistance and connect between V_{RF} connector on rear panel of power meter and pin 1 on thermistor mount end of power meter interconnect cable.

(2) Round off multimeter indication two decimal places and record this value as internal bridge resistance R of power meter (approximately 200Ω).

(3) Reconnect thermistor mount to power meter interconnect cable and connect equipment as shown in figure 6.

(4) Press **TI LINE** pushbutton to **ON** and **POWER REF** pushbutton to off. Set power meter switch to on and wait 30 minutes for thermistor mount to stabilize before proceeding.

(5) Set power meter **RANGE** switch to **COARSE ZERO** and adjust front panel **COARSE ZERO** control for a zero meter indication.

(6) Zero power meter on the most sensitive range, then set power meter **RANGE** switch to **1 mW**

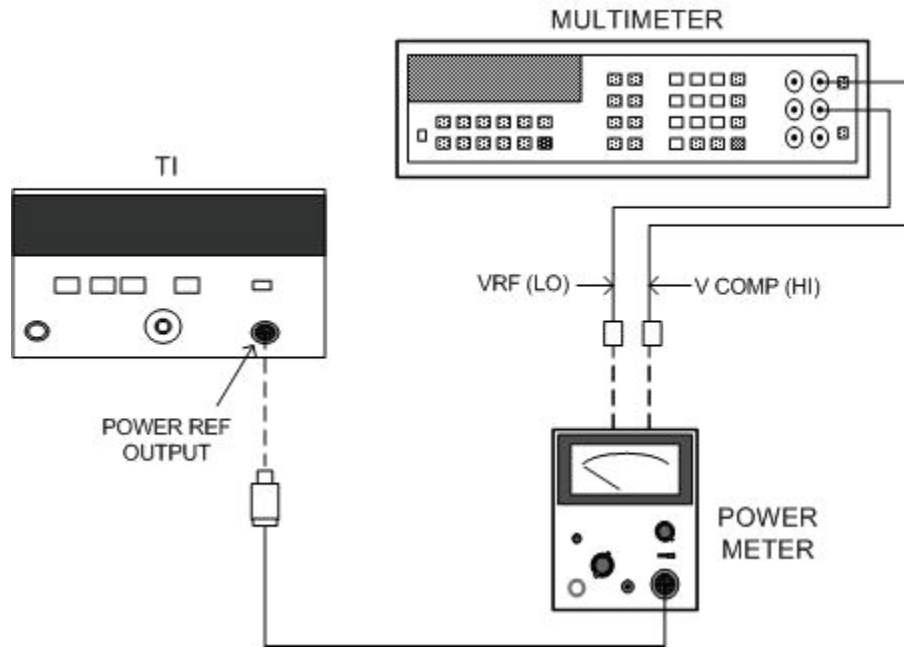

Figure 6. Power reference level - equipment setup.

NOTE

Ensure that multimeter input leads are isolated from chassis ground when performing (7) below.

(7) Adjust multimeter to measure microvolts and connect positive and negative input leads, respectively, to V_{COMP} and V_{RF} connectors on rear panel of power meter.

(8) If multimeter indicates less than 400 microvolts, record indication and proceed to (9) below. If 400 microvolts or greater, press and hold power meter **FINE ZERO** switch and adjust **COARSE ZERO** control so that multimeter indicates 200 microvolts or less. Record indication. Release **FINE ZERO** switch and proceed to (9) below.

(9) Round off indication recorded in (8) above to the nearest microvolt and record this value as V_0 .

(10) Set TI **POWER REF** switch to **ON** (in) and record multimeter indication as V_1 .

(11) Disconnect multimeter negative input lead from the V_{RF} connector on power meter and reconnect to power meter chassis ground. Record multimeter indication as V_{COMP} .

(12) Calculate the power reference oscillator output level (P_{RF}) from the following formula:

$$P_{RF} = \frac{2 V_{COMP} (V_1 - V_0) + V_0^2 - V_1^2}{4 R \text{ (Calibration Factor)}}$$

Where:

P_{RF} = power reference oscillator output level

V_{COMP} = value recorded in (11) above

V_1 = value recorded in (10) above

V_0 = value recorded in (9) above

R = value recorded in (3) above

CALIBRATION FACTOR = value for thermistor mount at 50 MHz

(13) If calculated PRF is not between 0.993 and 1.007 mW, perform **b** below.

b. Adjustments. Remove TI top cover and set TI **POWER REF** switch to **ON** (in) and adjust A8R4 LEVEL (fig. 5) so that calculated PRF in **a** (13) above is 1 mW.

16. Final Procedure

- a.** Deenergize and disconnect all equipment.
- b.** Annotate and affix DA label/form in accordance with TB 750-25.

By Order of the Secretary of the Army:

Official:



JOYCE E. MORROW
*Administrative Assistant to the
Secretary of the Army*

0732304

GEORGE W. CASEY, JR.
*General, United States Army
Chief of Staff*

Distribution:

To be distributed in accordance with the initial distribution number (IDN) 342201, requirements for calibration procedure TB 9-6625-2050-24.

INSTRUCTIONS FOR SUBMITTING AN ELECTRONIC 2028

The following format must be used if submitting an electronic 2028. The subject line must be exactly the same and all fields must be included; however, only the following fields are mandatory: 1, 3, 4, 5, 6, 7, 8, 9, 10, 13, 15, 16, 17, and 27.

From: "Whomever" whomever@redstone.army.mil
To: <2028@redstone.army.mil

Subject: DA Form 2028

1. **From:** Joe Smith
2. **Unit:** home
3. **Address:** 4300 Park
4. **City:** Hometown
5. **St:** MO
6. **Zip:** 77777
7. **Date Sent:** 19-OCT -93
8. **Pub no:** 55-2840-229-23
9. **Pub Title:** TM
10. **Publication Date:** 04-JUL-85
11. **Change Number:** 7
12. **Submitter Rank:** MSG
13. **Submitter FName:** Joe
14. **Submitter MName:** T
15. **Submitter LName:** Smith
16. **Submitter Phone:** 123-123-1234
17. **Problem:** 1
18. **Page:** 2
19. **Paragraph:** 3
20. **Line:** 4
21. **NSN:** 5
22. **Reference:** 6
23. **Figure:** 7
24. **Table:** 8
25. **Item:** 9
26. **Total:** 123
27. **Text**

This is the text for the problem below line 27.

